

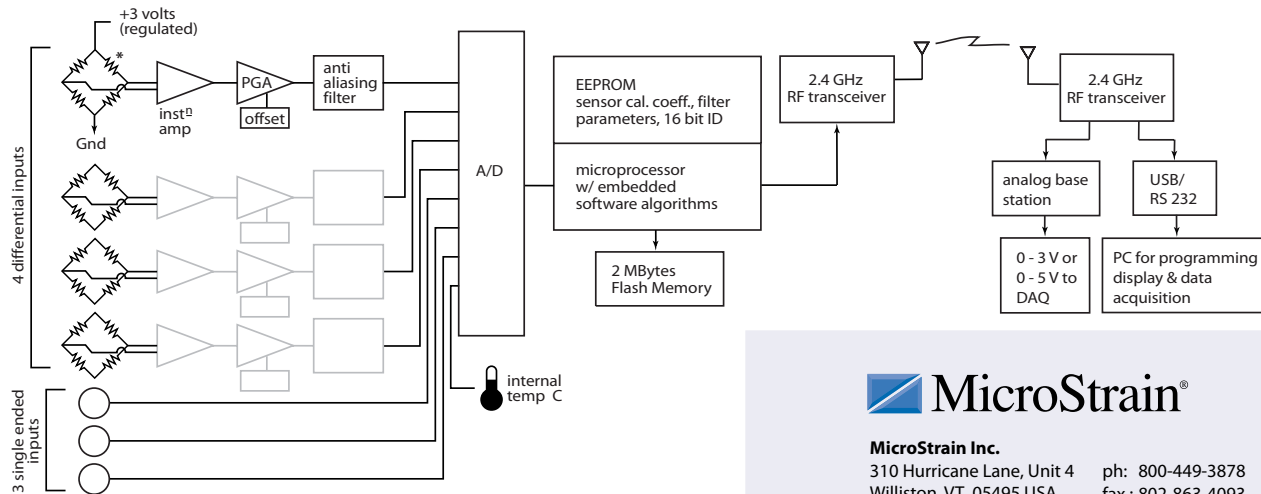



## Specifications

Input channels	up to 8 input channels: 4 full differential, 350 Ω resistance or higher (with optional bridge completion), 3 single ended inputs (0-3 volts maximum), and internal temperature sensor
Temperature sensor (channel 8)	-25 °C to 70 °C range, accuracy ± 4 °C
Measurement Accuracy	± 0.1% typical
Resolution	± 1 bit (0.024%)
DC bridge excitation	+3 volts DC at 50 mA maximum (pulsed to sensors for sample rates of 100 Hz and below to conserve power)
Programmable gain	software programmable for differential input channels from 208 to 4845 (can be reduced with hardware resistor change)
Programmable offset	software programmable , maximum allowable input offset is ±1.5 volts
Analog to digital (A/D) converter	successive approximation type, 12 bit resolution
Data storage capacity	2 megabytes (approximately 1,000,000 data points)
Data logging mode	log up to 1,000,000 data points (from 100 to 65,500 samples or continuous) at 32 Hz to 2048 Hz
Sensor event driven trigger	commence datalogging when threshold exceeded
Real-time streaming mode	transmit real time data from node to PC - rate depends on number of active channels: 1 channel - 4 KHz, 2 channels - 2 KHz, 3 channels - 1.33 KHz, 4 channels - 1 KHz, 5 channels - 800 Hz, 6 channels - 666 Hz, 7 channels - 570 Hz, 8 channels - 500 Hz
Low duty-cycle mode	supports multiple nodes on single RF channel, total update bandwidth of 500 Hz divided by number of nodes
Synchronization between nodes	datalogging 100 µsec ±50 ppm, LDC mode time stamped at PC
Sample rate stability	datalogging and LDC mode (2Hz to 500 Hz) ±25 ppm (90 msec/hour) LDC mode (1 Hz to 2 samples /hour) ±10%
Wireless shunt calibration	channels 1 to 4. Internal shunt calibration resistor 499 KΩ
Radio frequency (RF) transceiver carrier	2.4 GHz direct sequence spread spectrum, license free worldwide (2.450 to 2.490 GHz) - 16 channels
RF data packet standard	IEEE 802.15.4, open communication architecture
RF programming & downloading	8 minutes to download full memory
Range for bi-directional RF link	70 m line-of-sight, up to 300 m with optional high gain antenna
Internal Li-Ion battery	3.7 volt lithium ion rechargeable battery, 600 mAh capacity. Customer may supply external power from 3.2 to 9 volts
Power consumption	V-Link node only: real-time streaming - 25 mA, datalogging - 25 mA, sleeping - 0.5 mA External sensors: 350 Ω strain gauge - 8 mA, 1000 Ω strain gauge - 3 mA (add sensor consumption to above to calculate total power consumption)
Operating temperature	-20 to +60 °C with standard internal battery and enclosure, extended temperature range optional with custom battery and enclosure. -40 to +85 °C for electronics only
Dimensions	88 mm x 72 mm x 26 mm including mounting tabs and screw terminal block input connector (board only 72 mm x 65 mm x 24 mm) For dimensioned print go to <a href="http://www.microstrain.com">www.microstrain.com</a>
Weight	97 grams
Case	ABS plastic
Software	Agile-Link™ Windows XP compatible
PC Comm	serial port, 115.2 kbaud



\* Optional on-board bridge completion



**MicroStrain Inc.**

310 Hurricane Lane, Unit 4  
Williston, VT 05495 USA  
[www.microstrain.com](http://www.microstrain.com)

ph: 800-449-3878

fax: 802-863-4093

[sales@microstrain.com](mailto:sales@microstrain.com)