

ANDILOG**CENTOR Digital Graphic Force Gauge**
EASY Version

Simple and complete, the SAMSON "Easy" is the best instrument for measuring in the workshop. The screen provides simultaneous readout of the current and maximum values as well as a bar graph, advising the operator if he/she is close to maximum capacity. **The tolerance range functions also make it possible to conduct "Pass, Fail" tests, to stop a motorised stand or protect the sensor.** The RS232 and Digimatic ports allow for data transfer to a PC or a printer.

Technical features:

- Resolution 1/10,000, (5-digits)
- Accuracy: 0.1 %
- **Data Capture Rate: 1,000 hertz**
- **Large back-lighted graphic screen**
- Peak calculations
- **Simultaneous display of current and peak values**
- Bargraph value display
- **Selectable measurement units: N, daN, gf, Kgf, lb, oz, kN**
- Low battery warning
- Configuration stored in non-volatile memory
- 8 hours of operation without recharging thanks to its "automatic shutoff" and "sleep" modes
- Settable tolerance ranges with opening of external contact
- **Recall of last calibration date**
- **Steel casing with rubberised protection**
- Includes carrying case with accessories and charger
- M-5 threaded fixing holes for stand mounting
- **RS232, Digimatic and Analogic outputs**



The ideal tool for simple production testing!

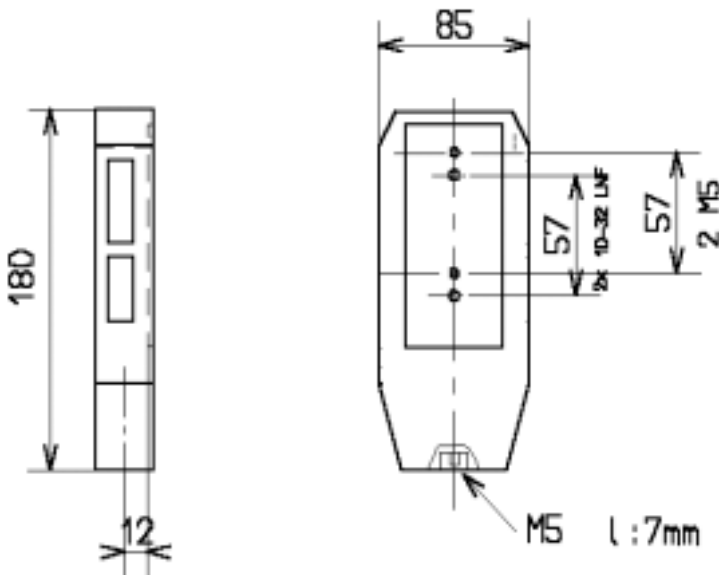

Reference	Capacity	Resolution
CNR EA 10	10 N	0,001
CNR EA 25	25 N	0,002
CNR EA 50	50 N	0,005
CNR EA 100	100 N	0,01
CNR EA 250	250 N	0,02
CNR EA 500	500 N	0,05
CNR EA 1000	1000 N	0,01