

CENTOR DUAL

Thanks to its ability to read two sensors simultaneously with a sampling rate of 1 000 Hertz, the CENTOR Dual is a real test console. It has all the functions of a CENTOR Star force gauge, but its calculation power enables it to record values sent by 2 different sensors simultaneously, monitor set points and make a calculation on each channel.

It can also show an F1/F2 graph or a force/displacement graph on its display, because it is also able to read potentiometric rulers and incremental encoders.

Technical features:

- **Simultaneous reading on 2 channels**
- Operate in tension and compression
- Resolution 1/10,000, (5-digits)
- Accuracy: 0.1 %
- Data Capture Rate: 1,000 hertz
- Large back-lighted graphic screen
- Peak calculations
- **Simultaneous display of current and peak values**
- Bargraph value display
- **Selectable measurement units: N, daN, gf, Kgf, lb, oz,**
- Low battery warning
- Configuration stored in non-volatile memory
- 8 hours of operation without recharging thanks to its "automatic shutoff " and "sleep" modes
- Settable tolerance ranges with opening of external contact
- **Recall of last calibration date**
- **Steel casing with rubberised protection**
- Includes carrying case with accessories and charger
- **RS232, Digimatic and Analogic outputs**

Special features:

- **Display of Force/Time curve**
- **Calculations:**
 - ✓ Force at time T or on a time frame
 - ✓ Differential Coefficient
 - ✓ Force at opening / closing of contact
 - ✓ Maximum value
 - ✓ Break
 - ✓ First Peak
 - ✓ Average Force
 - ✓ Last curve measured stored in memory
- Possibility to control test stands
- **Recognition of incremental displacement sensors**
- System of sensor recognition allowing a single instrument to read different sensors

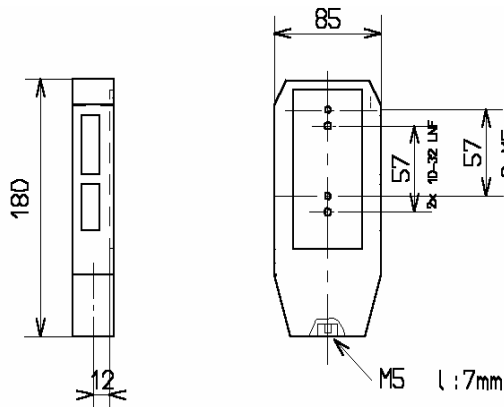

Reference	Capacity	Resolution
CNR DL 5	5 N	0.0005 N
CNR DL 10	10 N	0,001 N
CNR DL 25	25 N	0,002 N
CNR DL 50	50 N	0,005 N
CNR DL 100	100 N	0,01 N
CNR DL 250	250 N	0,02 N
CNR DL 500	500 N	0,05 N
CNR DL 1000	1000 N	0,1 N